

\* 2-Stage Horizontal Transfer Caset

\* Pneumatic Shifter

\* 3-5 Output Feature

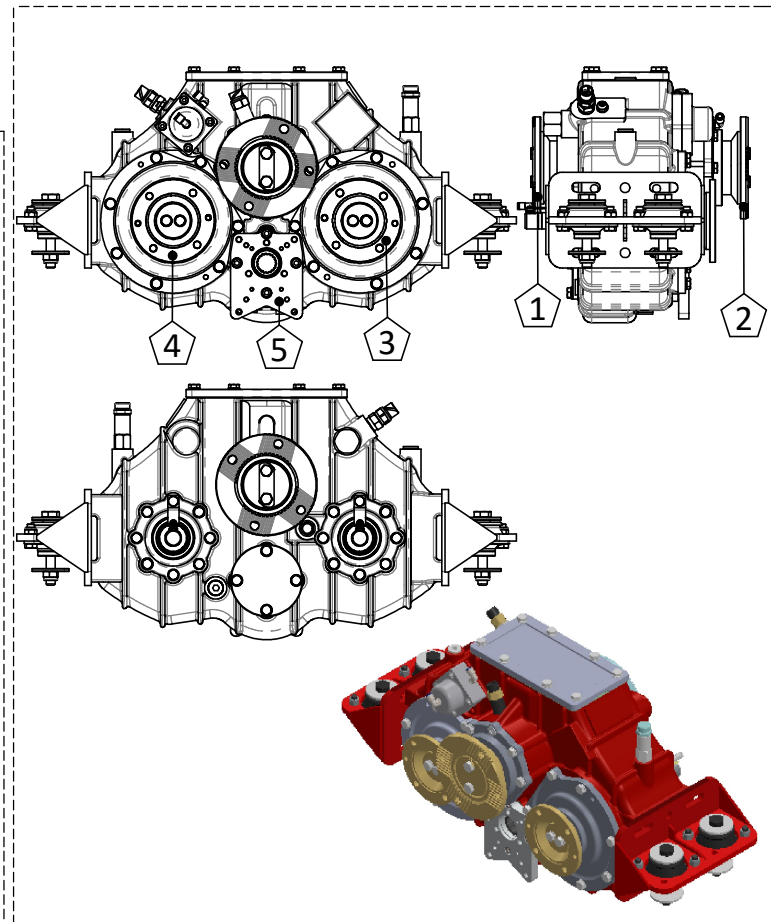
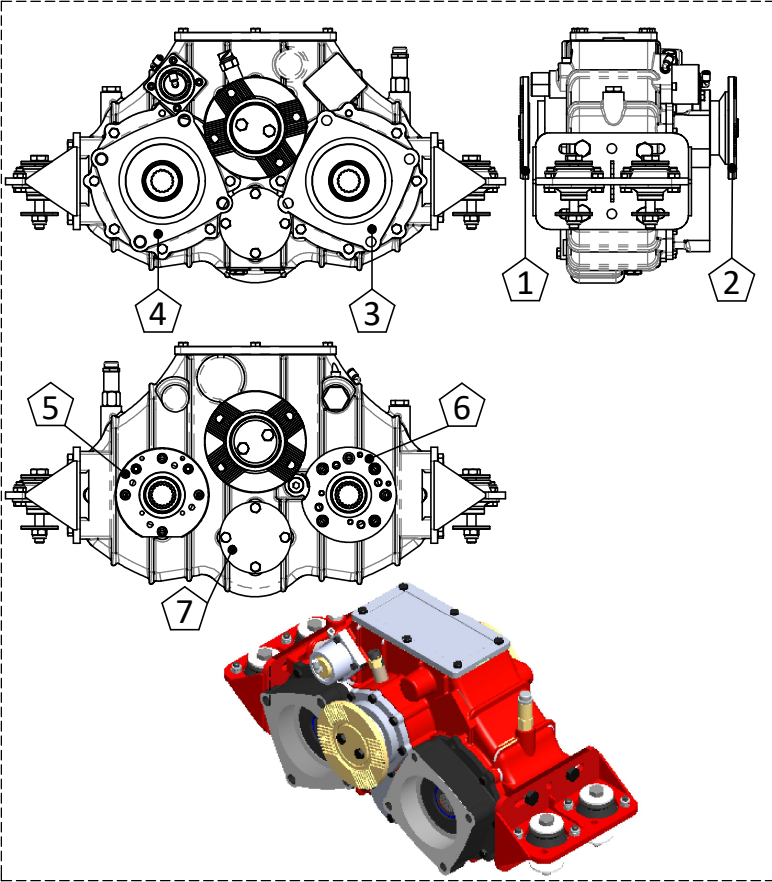

Structural Information	UARA.2401	UARA.2400
Axis Count	2 Stage	2 Stage
Distance between the main and secondary exit shafts	190 mm (7.48")	190 mm (7.48")
Max Power - Top output shafts (4) & (5)	200 Kw (268 HP)	350 Kw (470 HP)
Max Torque (Intermittent)- Input Shaft (1) & (2)	30,000 Nm (22,125 lb.Ft)	30,000 Nm (22,125 lb.Ft)
Max Torque (Continues)- Input Shaft (1) & (2)	22,500 Nm (16,595 lb.Ft)	22,500 Nm (16,595 lb.Ft)
Speed Ratio - Input shaft (1) & (2)	1:1	1:1
Speed Ratio - Top output shaft / UARA.3008 (4&5) / UARA.3005 (4)	1/1- 1/1.25 - 1/1.7	1/1- 1/1.25 - 1/1.7
Weight - Approx.	190 Kg (420 lb.)	190 Kg (420 lb.)
Max Speed - Top output shaft (4) & (5)	3500 Rpm	3500 Rpm
Clutch shift - Top output shaft UARA.3008 (4&5) / UARA.3005 (4)	-----	Standart
Connection options - Top&Centre output (3) & (4) & (5) UARA.2400 (3 & 4 & 5) / UARA.2400 (3 & 4 & 5 & 6 & 7)	SAE C-D - ISO pump & Flange	SAE A-B - ISO pump & Flange